

## Prestomatic Air Brake Push-In Fittings

### Advantages

Patented<sup>†</sup> design of Sizes 5/32" and above meet D.O.T. FMVSS 571.106 air brake performance specifications. No special tools are needed to assemble. Just bottom the tubing in the fitting body for a positive seal. Stainless steel tube support in sizes 1/4" and above assures maximum flow and performance requirements of SAE J1131. 1/8" Prestomatic<sup>†</sup> is designed for use in pressure protected air accessory lines that are isolated from the air brake system.

### Application

Use with Parker Parflex SAE J844 type A & B nylon tubing. Designed for all D.O.T. truck and trailer applications. Consult the factory with any questions regarding special product applications. Prior to use, all applications should be carefully tested through the range of conditions which may be encountered.

### Features

1. All brass body.
2. Stainless steel tube support assures maximum flow and performance characteristics.
3. Elbows and tees are available in swivel or rigid dryseal pipe threads. Swivels are designed for alignment purposes only.
4. Lubricated O-Ring Seal (Buna N) insures a quick, easy and positive seal.
5. Innovative Collet design insures positive grip on tubing.
6. Release Button offers quick and easy disconnections.

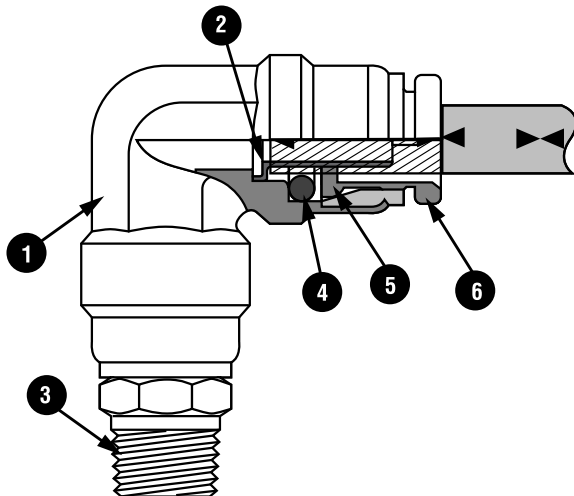

### Technical Data

- Working pressure from vacuum to 250 psi.
- Working temperature from -40° F to +200° F (Note: see tubing manufacturer's recommendations for pressure and temperature limitations).
- Buna N (Nitrile) O-Rings.

### Order

By part number and name.

### Nomenclature

Part numbers are constructed from symbols that identify the style and size of the fitting. The first series of numbers and letters identify the style and type of fitting. The Prestomatic series 1/4" and above has a stainless steel tube support and is designated with a "PMT" suffix. The Prestomatic series in sizes 1/8", 5/32", and 3/16" does not have a tube support and is designated with a "PM" suffix.

### Example:

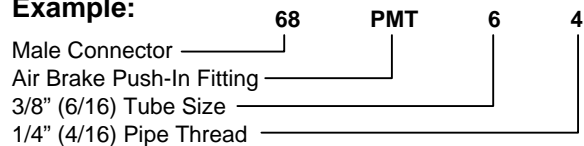

### Special Fittings

Fitting configurations and/or sizes other than those shown in the catalog can be furnished. It is suggested that a print or sketch be submitted with the inquiry. Price and delivery for non-stock items furnished on request for specified quantities.

### Pricing

Only items priced in current supplementary price list PL3501 are carried in stock. Price and delivery for non-stock items furnished on request for specified quantity.

<sup>†</sup> U.S. Patent No. 5,683,120

**Assembly Instructions**

1. Cut tubing squarely—maximum of 15° angle allowable.
  - If using Parker premarked tubing cut should be in center of bowtie symbol.
  - Use of Parker tube cutter PTC-001 is recommended.
2. Check that port or mating part is clean and free of debris.
3. Insert tubing into fitting until it bottoms.
  - Push twice to verify that tubing is inserted past collet and O-Ring.
  - If pre-marked tubing is used, the top of the button should be in the center of the bowtie
4. Pull on tubing to verify it is fully inserted.
5. To disassemble, simply press release button, hold against body, and pull tubing out of fitting.

Note: in order to pass hot pull requirements of SAE J1131 a stainless steel tube support must be present in the end of the fitting before final fitting assembly.

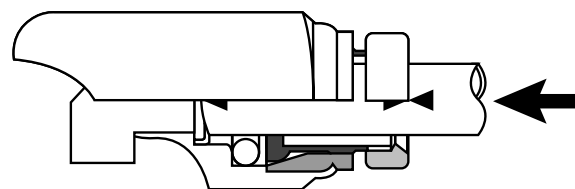
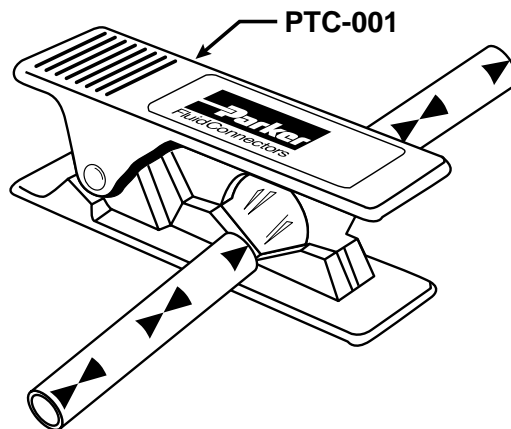

Insert tubing until it bottoms

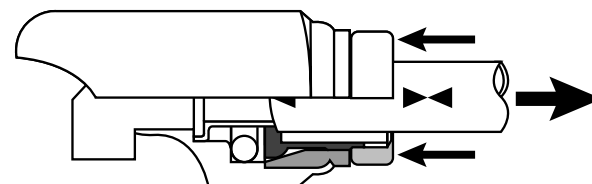

Depress button to remove tubing

**Pre-Marked Tubing Nomenclature**

\*P F T - 4 A - G R N - 1 0 0 0

<p><b>HOSE OR TUBING SIZE</b></p> <p>4A 6B 8B 10B</p>	<p><b>COLOR</b></p> <p>GRN BLU BLK YEL ORG RED ETC.</p>	<p><b>LENGTH (FEET)</b></p> <p>1 0 0 0</p>
---	---	--

\*Order from Parker Parflex Division

† U.S. Patent No. 5,683,120

**Prestomatic<sup>†</sup> Retaining Ring Bulkhead Unions**

Prestomatic<sup>†</sup> retaining ring bulkhead unions feature a unique design that provides the user with an economical method to install and assemble a union connection through a bulkhead.

The retaining ring bulkhead unions feature a smaller envelope size than standard bulkhead union connectors and do not require a wrench to mount or assemble in cramped areas.

The external seal feature provides a moisture barrier and can also prevent external contamination from entering into an enclosed area.

To install, simply support the bulkhead union from behind and apply the external seal. Then push the external retainer against the external seal with an assembly tool and you have a reliable bulkhead connection in a confined area.

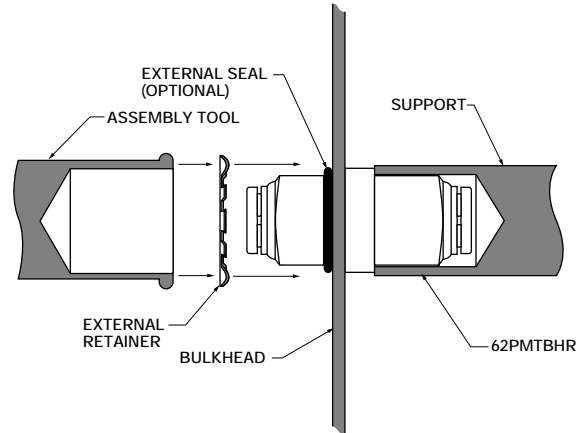

**Retaining Ring Bulkhead 62PMTBHR**

PART NO.	TUBE SIZE	O.D.	REC. HOLE SIZE	L	P MAX	A DIA
62PMTBHR-4	1/4	.500	.512	1.53	.26	.625
62PMTBHR-6	3/8	.750	.762	1.92	.36	.875
62PMTBHR-8	1/2	.875	.887	2.15	.43	1.000
62PMTBHR-10	5/8	1.000	1.012	2.54	.62	1.250

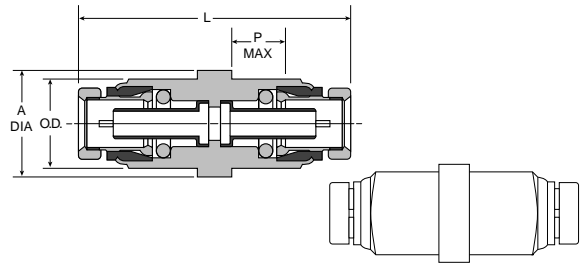

**External Retainer ERHD\***

PART NUMBER	TUBE SIZE	BULKHEAD UNION O.D.	A DIA	W
ERHD-50	1/4	.500	.83	.05
ERHD-75	3/8	.750	1.08	.05
ERHD-87	1/2	.875	1.20	.05
ERHD-100	5/8	1.000	1.33	.05

\*Material Carbon Spring Steel

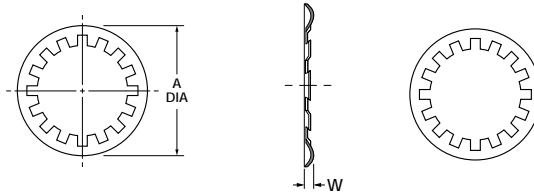

**External Seal ES\***

PART NUMBER	TUBE SIZE	BULKHEAD UNION O.D.	I.D.	W
ES-50	1/4	.500	.489	.07
ES-75	3/8	.750	.739	.07
ES-87	1/2	.875	.864	.07
ES-100	5/8	1.000	.989	.07

\*Material is Nitrite (Buna N), 70 Durometer

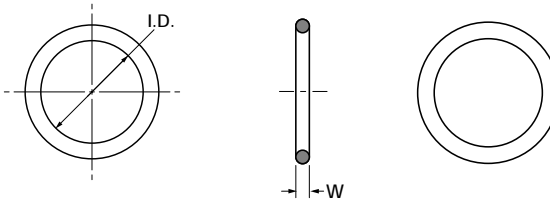

**Union 62PM**

PART NO.	TUBE SIZE	L	O.D.
62PM-2	1/8	1.60	0.406
62PM-5/32	5/32	1.60	0.406
62PM-3	3/16	1.35	0.440

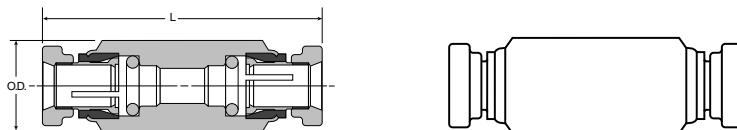

<sup>†</sup> U.S. Patent No. 5,683,120

# Prestomatic† Air Brake Push-In Fittings

## Union 62PMT

PART NO.	TUBE SIZE	L	O.D.
62PMT-4	1/4	1.48	.50
62PMT-4-2	1/4-1/8	1.48	.50
62PMT-6	3/8	1.87	.75
62PMT-6-4	3/8-1/4	1.68	.75
62PMT-8	1/2	2.03	.88
62PMT-10	5/8	2.42	1.00

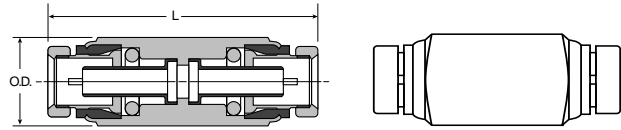

## Bulkhead Union 62PMTBH

PART NO.	TUBE SIZE	O.D.	L	P MAX	HEX A	HEX B
62PMTBH-4	1/4	.56	1.69	.25	11/16	3/4
62PMTBH-6	3/8	.88	1.93	.44	1-1/16	1-1/16
62PMTBH-8	1/2	1.00	2.02	.58	1-1/4	1-1/4
62PMTBH-10	5/8	1.12	2.92	.81	1-1/4	1-3/8

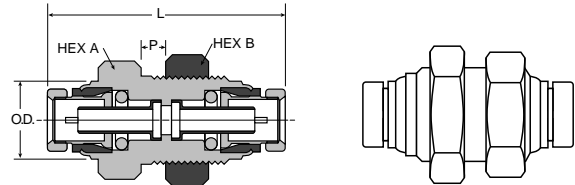

## Female Connector 66PMT

PART NO.	TUBE SIZE	PIPE THREAD	L	HEX
66PMT-4-2	1/4	1/8	1.22	9/16
66PMT-4-4	1/4	1/4	1.43	11/16
66PMT-6-2	3/8	1/8	1.37	3/4
66PMT-6-4	3/8	1/4	1.58	3/4
66PMT-6-6	3/8	3/8	1.62	13/16
66PMT-8-4	1/2	1/4	1.69	7/8
66PMT-8-6	1/2	3/8	1.68	7/8
66PMT-8-8	1/2	1/2	1.91	1

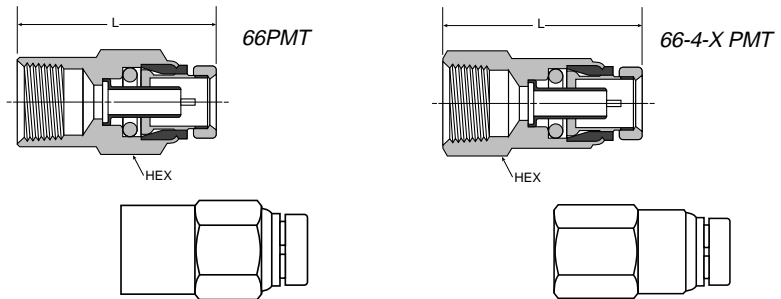

## Bulkhead Female Connector 66PMTBH

PART NO.	TUBE SIZE	PIPE THREAD	L	HEX A	HEX B
66PMTBH-4-4	1/4	1/4	1.62	11/16	3/4
66PMTBH-6-6	3/8	3/8	1.87	1.06	1.06
66PMTBH-8-8	1/2	1/2	2.02	1-1/4	1-1/4

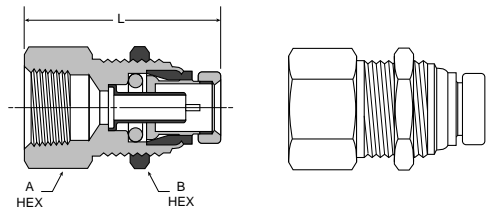

## Male Connector 68PM

PART NO.	TUBE SIZE	PIPE THREAD	HEX	L
68PM-2-1	1/8	1/16	3/8	.93
68PM-2-2	1/8	1/8	7/16	.88
68PM-5/32-1	5/32	1/16	3/8	.95
68PM-5/32-2	5/32	1/8	7/16	.74
68PM-5/32-4	5/32	1/4	9/16	.99
68PM-3-1	3/16	1/16	7/16	.95
68PM-3-2	3/16	1/8	7/16	.92
68PM-3-4	3/16	1/4	9/16	1.10

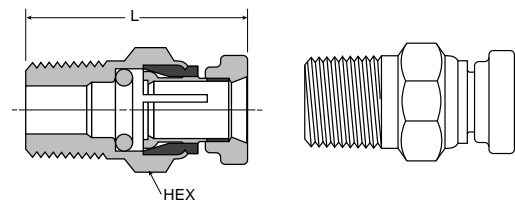

† U.S. Patent No. 5,683,120

**Male Connector 68PMT**

PART NO.	TUBE SIZE	PIPE THREAD	L	HEX
68PMT-4-2	1/4	1/8	1.06	1/2
68PMT-4-4	1/4	1/4	1.19	9/16
68PMT-4-6	1/4	3/8	1.27	3/4
68PMT-6-2	3/8	1/8	1.37	3/4
68PMT-6-4	3/8	1/4	1.43	3/4
68PMT-6-6	3/8	3/8	1.33	3/4
68PMT-6-8	3/8	1/2	1.38	7/8
68PMT-8-4	1/2	1/4	1.43	7/8
68PMT-8-6	1/2	3/8	1.52	7/8
68PMT-8-8	1/2	1/2	1.44	7/8
68PMT-10-6	5/8	3/8	1.88	1
68PMT-10-8	5/8	1/2	1.88	1
68PMT-12-8	3/4	1/2	2.03	1 3/16

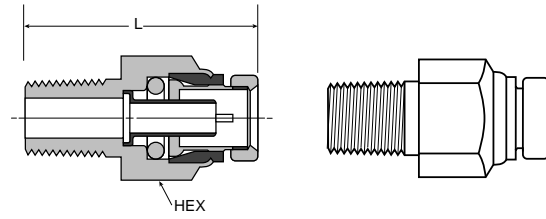

**Bulkhead Male Connector 68PMTBH**

PART NO.	TUBE SIZE	PIPE THREAD	L	P MAX	HEX A	HEX B
68PMTBH-6-8	3/8	1/2	2.37	.33	1-1/4	1-1/4
68PMTBH-8-8	1/2	1/2	2.38	.33	1-1/4	1-1/4

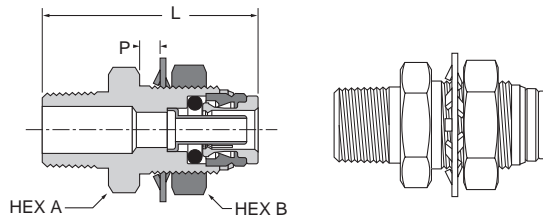

**Union Tee 164PM**

PART NO.	TUBE SIZE	L1	WRENCH FLATS
164PM-2	1/8	.81	.42

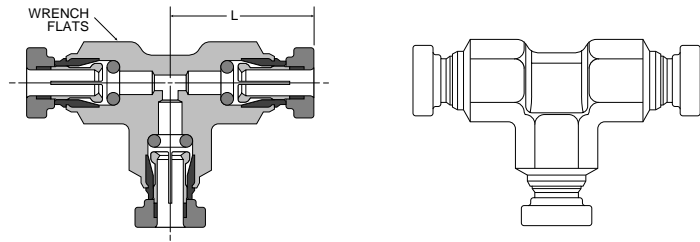

**Union Tee 164PMT**

PART NO.	TUBE 1 SIZE	TUBE 2 SIZE	L1	L2
164PMT-4	1/4	1/4	.85	.85
164PMT-6	3/8	3/8	1.21	1.21
164PMT-6-6-4	3/8	1/4	1.21	.93
164PMT-8	1/2	1/2	1.27	1.27
164PMT-10	5/8	5/8	1.63	1.62

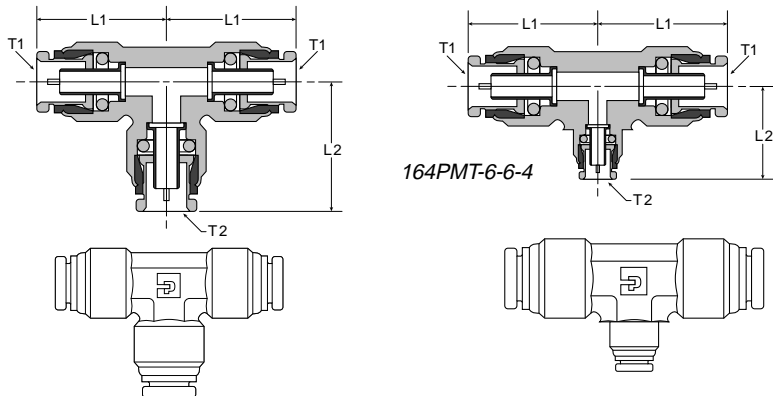

† U.S. Patent No. 5,683,120

# Prestomatic† Air Brake Push-In Fittings

## Union Elbow 165PMT

PART NO.	TUBE SIZE	L
165PMT-4	1/4	.85
165PMT-6	3/8	1.11
165PMT-8	1/2	1.24
165PMT-10	5/8	1.57

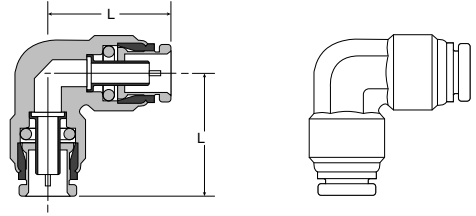

## Male Elbow Non-Swivel 169PMNS

PART NO.	TUBE SIZE	PIPE THREAD	L	N	WRENCH FLATS
169PMNS-2-2	1/8	1/8	.86	.68	3/8
169PMNS-5/32-2	5/32	1/8	.88	.68	3/8
169PMNS-3-2	3/16	1/8	.75	.67	3/8
169PMNS-3-4	3/16	1/4	.74	.93	1/2

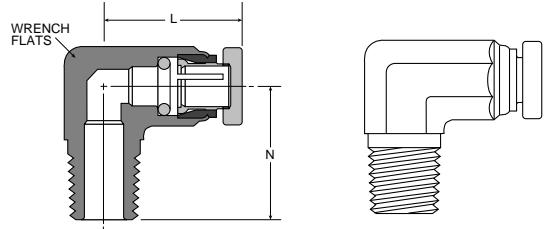

## Male Elbow Swivel 90° 169PMT

PART NO.	TUBE SIZE	PIPE THREAD	L	N	WRENCH FLATS	HEX B
169PMT-4-2	1/4	1/8	.84	1.21	13/32	7/16
169PMT-4-4	1/4	1/4	.84	1.43	13/32	9/16
169PMT-4-6	1/4	3/8	.84	1.43	13/32	11/16
169PMT-6-2	3/8	1/8	1.11	1.41	9/16	9/16
169PMT-6-4	3/8	1/4	1.11	1.58	9/16	5/8
169PMT-6-6	3/8	3/8	1.11	1.58	9/16	11/16
169PMT-6-8	3/8	1/2	1.11	1.79	9/16	7/8
169PMT-8-4	1/2	1/4	1.27	1.73	11/16	5/8
169PMT-8-6	1/2	3/8	1.27	1.81	11/16	3/4
169PMT-8-8	1/2	1/2	1.27	1.96	11/16	7/8
169PMT-10-6	5/8	3/8	1.53	2.03	7/8	3/4
169PMT-10-8	5/8	1/2	1.53	2.18	7/8	7/8

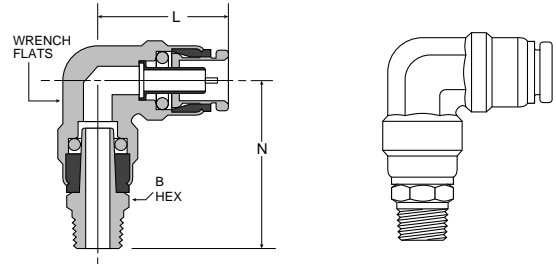

## Male Elbow Long Non-Swivel 90° 169PMTL

PART NO.	TUBE SIZE	PIPE THREAD	L	N	WRENCH FLATS
169PMTL-6-4	3/8	1/4	1.06	1.63	9/16
169PMTL-6-8	3/8	1/2	1.19	2.50	7/8
169PMTL-8-8	1/2	1/2	1.22	2.50	7/8
169PMTL-10-8	5/8	1/2	1.46	2.50	7/8

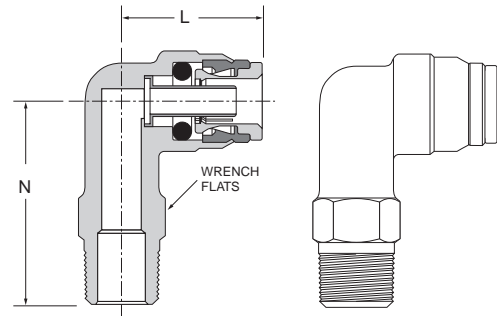

† U.S. Patent No. 5,683,120

**Male Elbow Non-Swivel 90° 169PMTNS**

PART NO.	TUBE SIZE	PIPE THREAD	L	N	WRENCH FLATS
169PMTNS-4-2	1/4	1/8	.84	.72	1/2
169PMTNS-4-4	1/4	1/4	.84	.90	1/2
169PMTNS-4-6	1/4	3/8	.84	1.06	1/2
169PMTNS-6-2	3/8	1/8	1.05	.75	9/16
169PMTNS-6-4	3/8	1/4	1.05	.94	9/16
169PMTNS-6-6	3/8	3/8	1.05	.94	3/4
169PMTNS-6-8	3/8	1/2	1.12	1.26	11/16
169PMTNS-8-4	1/2	1/4	1.17	1.06	11/16
169PMTNS-8-6	1/2	3/8	1.22	1.06	11/16
169PMTNS-8-8	1/2	1/2	1.22	1.26	11/16
169PMTNS-10-6	5/8	3/8	1.46	1.11	7/8
169PMTNS-10-8	5/8	1/2	1.46	1.32	7/8
169PMTNS-12-8	3/4	1/2	1.81	1.44	1

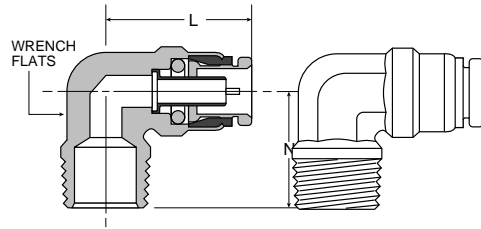

**Male Elbow Bulkhead 169PMTBH**

PART NO.	TUBE SIZE	PIPE THREAD	L	N	B HEX	C HEX	FLOW DIA. D
169PMTBH6-8	3/8	1/2	1.19	2.50	1-1/4	7/8	.22
169PMTBH8-8	1/2	1/2	1.29	2.50	1-1/4	7/8	.22

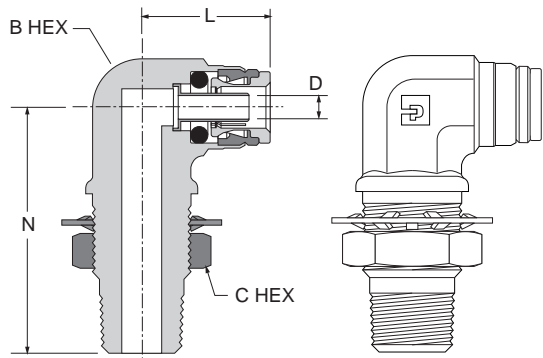

**Female Elbow Non-Swivel 90° 170PMTNS**

PART NO.	TUBE SIZE	PIPE THREAD	L	N	WRENCH FLATS
170PMTNS-4-2	1/4	1/8	.84	.56	11/16
170PMTNS-4-4	1/4	1/4	1.00	.67	11/16
170PMTNS-6-2	3/8	1/8	1.12	.64	9/16
170PMTNS-6-4	3/8	1/4	1.25	1.00	11/16
170PMTNS-6-6	3/8	3/8	1.25	1.00	13/16
170PMTNS-8-4	1/2	1/4	1.25	.75	11/16
170PMTNS-8-6	1/2	3/8	1.32	.88	11/16
170PMTNS-8-8	1/2	1/2	1.70	.98	1

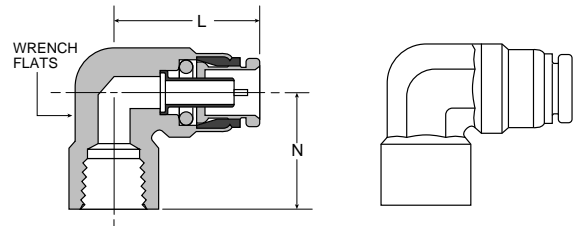

**Male Run Tee Swivel 171PMT**

PART NO.	TUBE SIZE	PIPE THREAD	L	N	HEX	WRENCH FLATS
171PMT-4-2	1/4	1/8	.85	1.25	7/16	1/2
171PMT-4-4	1/4	1/4	.85	1.48	9/16	1/2
171PMT-6-4	3/8	1/4	1.21	1.83	9/16	5/8
171PMT-6-6	3/8	3/8	1.21	1.83	11/16	5/8
171PMT-8-4	1/2	1/4	1.27	1.74	5/8	7/8
171PMT-8-6	1/2	3/8	1.27	1.83	3/4	7/8
171PMT-8-8	1/2	1/2	1.27	1.99	7/8	7/8

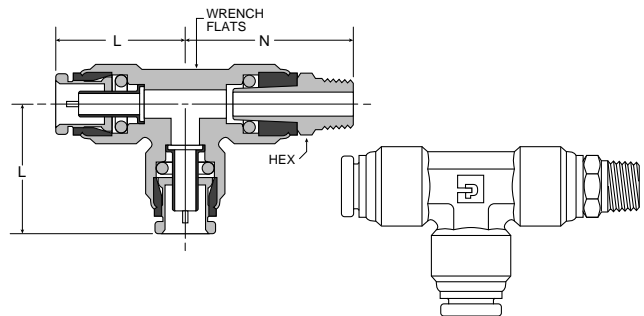

† U.S. Patent No. 5,683,120

# Prestomatic† Air Brake Push-In Fittings

## Male Run Tee Non-Swivel 171PMTNS

PART NO.	TUBE 1 SIZE	TUBE 2 SIZE	PIPE THREAD	L1	L2	N	WRENCH FLATS
171PMTNS-4-4	1/4	1/4	1/4	.91	.91	.94	15/32
171PMTNS-4-6-4	1/4	3/8	1/4	.93	1.21	.97	5/8
171PMTNS-6-4	3/8	3/8	1/4	1.21	1.21	.97	5/8
171PMTNS-6-4-4	3/8	1/4	1/4	1.21	.93	.97	5/8
171PMTNS-6-4-6	3/8	1/4	3/8	1.22	.97	.93	5/8
171PMTNS-6-6	3/8	3/8	3/8	1.21	1.21	.97	5/8
171PMTNS-6-8	3/8	3/8	1/2	1.17	1.17	1.26	5/8
171PMTNS-8-4	1/2	1/2	1/4	1.28	1.28	1.06	7/8

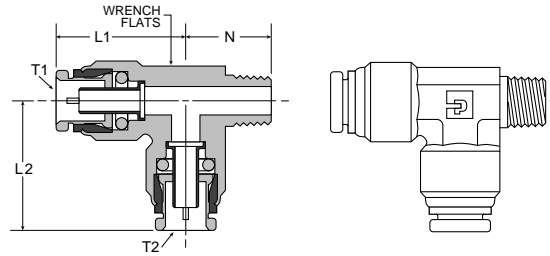

## Male Branch Tee Swivel 172PMT

PART NO.	TUBE SIZE	PIPE THREAD	L	N	HEX	WRENCH FLATS
172PMT-4-2	1/4	1/8	.85	1.25	7/16	1/2
172PMT-4-4	1/4	1/4	.85	1.43	9/16	1/2
172PMT-6-2	3/8	1/8	1.22	1.66	9/16	5/8
172PMT-6-4	3/8	1/4	1.22	1.83	5/8	5/8
172PMT-6-6	3/8	3/8	1.22	1.83	3/4	5/8
172PMT-8-4	1/2	1/4	1.27	1.73	5/8	7/8
172PMT-8-6	1/2	3/8	1.27	1.79	3/4	7/8
172PMT-8-8	1/2	1/2	1.27	1.97	7/8	7/8

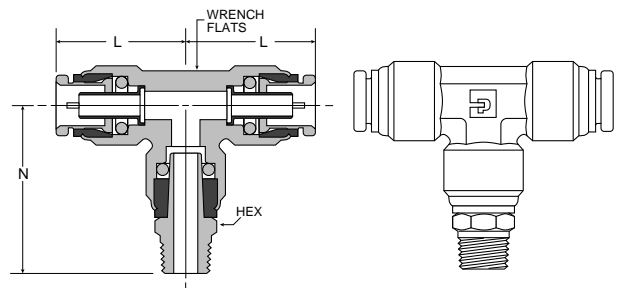

## Male Branch Tee Non-Swivel 172PMTNS

PART NO.	TUBE 1 SIZE	TUBE 2 SIZE	PIPE THREAD	L1	L2	N	WRENCH FLATS
172PMTNS-4-2	1/4	1/2	1/8	.91	.91	.78	1/2
172PMTNS-6-4	3/8	3/8	1/4	1.21	1.21	.97	5/8
172PMTNS-6-4-4	3/8	1/4	1/4	1.21	.93	.97	5/8
172PMTNS-6-6	3/8	3/8	3/8	1.21	1.21	.97	5/8
172PMTNS-6-8	3/8	3/8	1/2	1.17	1.17	1.26	7/8
172PMTNS-8-6	1/2	3/8	1/2	1.28	1.28	1.06	7/8
172PMTNS-8-8	1/2	1/2	1/2	1.34	1.34	1.25	7/8

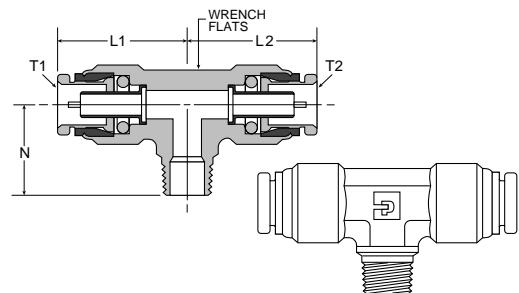

## Male Elbow Swivel 45° 179PMT

PART NO.	TUBE SIZE	PIPE THREAD	L	N	HEX	WRENCH FLATS
179PMT-4-2	1/4	1/8	.79	1.16	7/16	9/16
179PMT-4-4	1/4	1/4	.89	1.46	9/16	9/16
179PMT-6-2	3/8	1/8	.99	1.44	5/8	3/4
179PMT-6-4	3/8	1/4	.99	1.61	5/8	3/4
179PMT-6-6	3/8	3/8	.99	1.61	5/8	3/4
179PMT-8-4	1/2	1/4	1.20	1.70	5/8	7/8
179PMT-8-6	1/2	3/8	1.20	1.78	3/4	7/8
179PMT-8-8	1/2	1/2	1.20	1.93	7/8	7/8

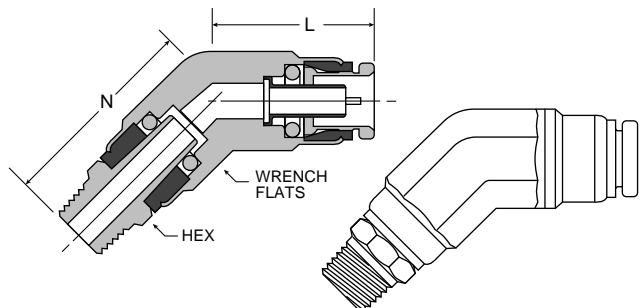

† U.S. Patent No. 5,683,120

**Male Elbow Non-Swivel 45° 179PMTNS**

PART NO.	TUBE SIZE	PIPE THREAD	L	N	WRENCH FLATS
179PMTNS-4-2	1/4	1/8	.80	.56	9/16
179PMTNS-4-4	1/4	1/4	.80	.75	9/16
179PMTNS-6-2	3/8	1/8	.99	.55	3/4
179PMTNS-6-4	3/8	1/4	.99	.73	3/4
179PMTNS-6-6	3/8	3/8	.99	.73	3/4
179PMTNS-8-4	1/2	1/4	1.28	.81	13/16
179PMTNS-8-6	1/2	3/8	1.28	.81	13/16
179PMTNS-8-8	1/2	1/2	1.28	1.06	13/16
179PMTNS-10-6	5/8	3/8	1.22	.88	1 1/16
179PMTNS-10-8	5/8	1/2	1.22	1.00	1 1/16
179PMTNS-12-8	3/4	1/2	1.41	1.25	1 5/16

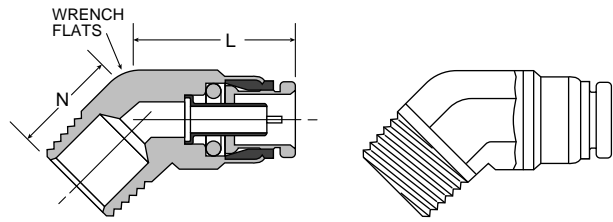

**Dual port 90° male elbow non-swivel 189PMT**

PART NO.	TUBE 1 SIZE	TUBE 2 SIZE	PIPE THREAD	L1	L2	N1	N2	WRENCH FLATS
189PMT4-4-4	1/4	1/4	1/4	1.91	.89	.95	.95	5/8
189PMT6-4-6	3/8	1/4	3/8	2.38	1.00	1.19	1.12	3/4
189PMT10-4-6	5/8	1/4	3/8	2.38	1.00	1.28	1.12	3/4
189PMT10-6-6	5/8	3/8	3/8	2.38	1.00	1.26	1.18	3/4

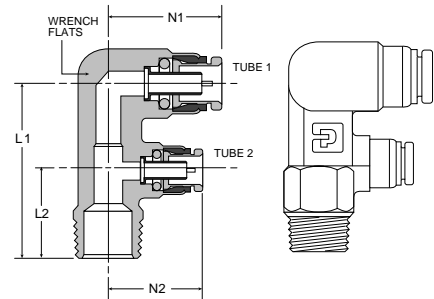

**Push-To-Connect Fitting Plug 639PM/639PMT**

PART NO.	TUBE SIZE	L	M	A	D
639PM-5/32	5/32	1.09	1.00	.39	.156
639PMT-4	1/4	1.14	.96	.48	.250
639PMT-6	3/8	1.33	1.15	.67	.375
639PMT-8	1/2	1.33	1.15	.81	.500

Specify color when ordering Black (BL) or Blue (BU), example 639PMT-4BU  
 Note: use appropriate PM/PMT style connection as determined by part number.

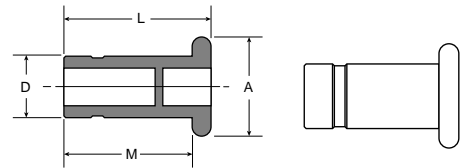

† U.S. Patent No. 5,683,120

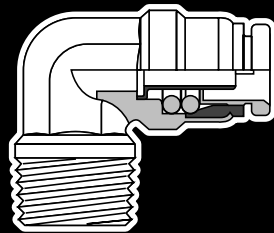

## Prestomatic Diesel Fuel Push-In Fittings

### Advantages

The Prestomatic Diesel Fuel Fitting is designed for use in truck diesel fuel systems. Each Fitting is 100% leak tested before shipment. No special tools are required to assemble. Just bottom the tubing in the fitting body for a positive seal.

### Application

Use with Parker Parflex Fuel SAE J844 type A & B nylon tubing. Designed for diesel fuel system applications. Consult the factory with any questions regarding special product applications. Prior to use, all applications should be carefully tested through the range of conditions which may be encountered.

### Features

1. All brass body.
2. Stainless steel tube support assures maximum flow and performance characteristics.
3. Elbows are available in rigid dryseal pipe threads.
4. Lubricated double o-ring seal (Buna N) insures a quick, easy and positive seal, virtually eliminating the chance for leakage.
5. Patented collet design insures positive grip on tubing.
6. Release button offers quick and easy disconnections.

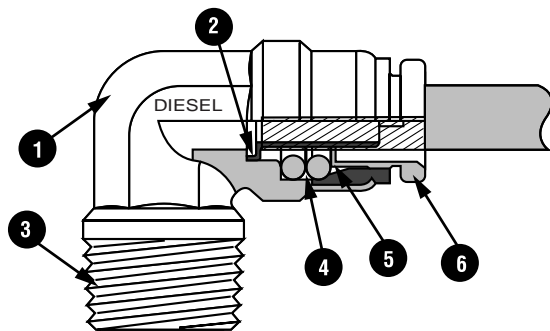

### Technical Data

- Working pressure from vacuum to 200 psi.
- Working temperature from -40° F to +200° F (Note: see tubing manufacturer's recommendations for pressure and temperature limitations).
- Two Buna N (Nitrile) O-Rings.
- For use with U.S. diesel no. 1 and 2, Canadian low sulfur .05% and high sulfur no. 1 diesel fuels.

### Order

By part number and name.

### Nomenclature

Part numbers are constructed from symbols that identify the style and size of the fitting. The first series of numbers and letters identify the style and type of fitting. The Diesel Fuel Fitting series is designed with a DFF suffix.

### Example:

Vibra Seal								
Male Connector								
Diesel Fuel Push-In Fitting								
1/2" Tube Size								
3/8" Pipe Thread								

### Special Fittings

Fitting configurations and/or sizes other than those shown in the catalog can be furnished. It is suggested that a print or sketch be submitted with the inquiry. Price and delivery for non-stock items furnished on request for specified quantities.

### Pricing

Only items priced in current supplementary price list PL3501 are carried in stock. Price and delivery for non-stock items furnished on request for specified quantity.

**Male Connector VS68DF**

PART NO.	TUBE SIZE	PIPE THREAD	L	HEX
VS68DF-8-4	1/2	1/4	1.69	7/8
VS68DF-8-6	1/2	3/8	1.58	7/8
VS68DF-8-8	1/2	1/2	1.63	7/8
VS68DF-10-6	5/8	3/8	1.86	1
VS68DF-10-8	5/8	1/2	1.86	1

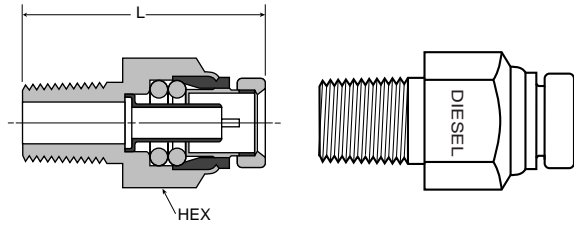

**Male Elbow Non-Swivel 90° VS169DFNS**

PART NO.	TUBE SIZE	PIPE THREAD	L	N	WRENCH FLATS
VS169DFNS8-4	1/2	1/4	1.25	1.06	11/16
VS169DFNS8-6	1/2	3/8	1.28	1.06	11/16
VS169DFNS8-8	1/2	1/2	1.28	1.26	11/16
VS169DFNS10-6	5/8	3/8	1.46	1.11	7/8

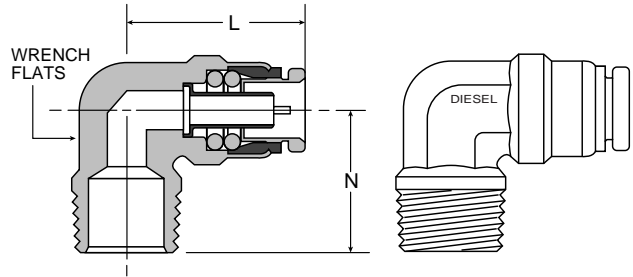

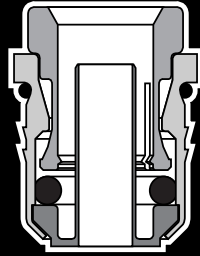

# Presto Encapsulated Cartridges

## Advantages

Parker Presto Encapsulated Cartridges are a compact, economical design that allows the user to eliminate the space and labor required to install and assemble a conventional pipe thread fitting connection. Weight reduction and the elimination of pipe thread leakage related to improper assembly techniques are also improved. The Presto Cartridge design allows for faster and easier installation of components and assemblies. An external o-ring is included assembled to the Presto Cartridge to insure a leak free cavity. The PMTCER includes a built in tube support. Once the Presto Cartridge is installed in a single step cavity, no special tools are needed to assemble. Just bottom the tubing into the cartridge body for a positive seal. For color coding use the PMCEN cartridge. After installation into a cavity, simply snap on the color coded release button onto the PMCEN Cartridge. The PMTCER requires no additional button assembly.

## Materials

Presto Encapsulated Cartridges are designed to be installed into a thermoplastic (Nylon/Glass Filled Nylon/Acetal) cavity. Consult factory for specific cavity or housing materials that would be suitable for a particular application.

## Applications

### Industrial (PMCEN, PMTCER)

Once the Presto Encapsulated Cartridge is installed into an approved cavity material, use with Parker Parflex series "E" polyethylene tubing, series "N" nylon tubing, series "U" polyurethane tubing or soft metal tubing in pneumatic instrumentation circuits and various industrial applications.

### Air Brake (PMCEN)

For Air Brake applications, use with Parker Parflex SAE J844 Type A and B nylon tubing. Sizes 5/32" and above meet D.O.T. FMVSS 571.106 air brake performance specifications. The addition of a stainless steel tube support (63 NTA) in sizes 1/4" and above assures that the cartridge assembly will meet the performance requirements of SAE J1131 and D.O.T. FMVSS 571.106. Consult factory for specific cavity or housing material to insure cartridge to cavity assembly will meet SAE J1131 requirements. 1/8" Presto Encapsulated Cartridges are designed for use in pressure protected air accessory lines that are isolated from the air brake system.

### Air Brake (PMT CER)

For Air Brake applications use with Parker Parflex SAE J844 Type A&B nylon tubing. PMTCER cartridges with a built in tube support meet performance requirements of D.O.T. FMVSS 571.106 and SAE J1131.

## Technical Data

- Working pressure from vacuum to 250 PSI
- Working temperature from -40°F to +200°F (Note: See tubing manufacturer's recommendations for pressure and temperature limitations.)
- Buna N (nitrile) O-Rings

## Tube Assembly Instructions

1. Cut Parker Parflex thermoplastic squarely using Parker tube cutter PTC-001. Metal Tubing should be cut square and free of burrs.
2. Insert end of tubing into cartridge until it bottoms. Pull on tubing to verify it is properly retained.
3. To disassemble, simply hold release button against the body and remove tubing.
4. To reassemble, lubricate leading end of the tubing with light oil or petroleum jelly.

## Order

By part number and name.

## Nomenclature

Part numbers are constructed from symbols that identify the style and size of the cartridge. Presto Encapsulated Cartridge buttons for the PMCEN are to be ordered separately from the cartridge and specified by color.

### Example:

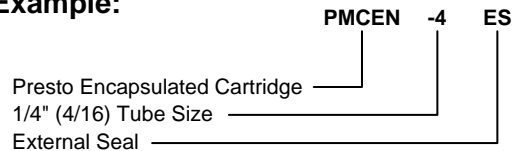

## Special Cartridges

Encapsulated cartridge configurations and/or sizes other than those shown in the catalog can be furnished. Non-standard o-ring materials available. It is suggested that a print or sketch be submitted with the inquiry. Price and delivery for non-stock items furnished on request for specified quantities.

† U.S. Patent No. 5,683,120

**PMCEN Features**

No tube support required to pass performance requirements of D.O.T. FMVSS 571.106 (PMCEN-532 & larger)

Low profile tube connections are the same height for all sizes, simplifying multiple tube size installations.

External seal

External barb design improves sealing capability.

Positive tube stop. Tube insertion depth is consistent with Prestomatic fittings.

Increased flow diameter due to elimination of tube support.

Housing

Inside Cavity

Optional color coded release buttons can be removed to prevent accidental release of tubing

Collet designed to prevent side load leakage

"Positive stop" shoulder insures that cartridges are installed to the proper depth

Encapsulated o-ring eliminates concerns for out-of-round cavity and damage during shipment

Self-aligning design allows for consistent installation.

Single diameter cavity

Chamfer required for external seal

- Working pressure: Vacuum to 250 psi (See tubing manufacturer's recommendations for pressure and temperature limitations.)
- Temperature Range: -40°F to 200°F
- Optional o-ring materials are available
- Fewer components to inventory
- Encapsulated design eliminates the accidental omission of components during cartridge installation.
- Color coding available
- No threads to leak resulting from improper assembly.
- No thread sealants to contaminate air system

**PMT CER Features**

Passes performance requirements of D.O.T. FMVSS 571.106 SAE J1131 in size 1/4" and above

Low profile tube connections are the same height for all sizes, simplifying multiple tube size installations.

External seal

External barb design improves sealing capability.

Positive tube stop. Same insertion depth as fitting

Plastic cavity

No special surface finished required.

Integrated button cannot be separated from cartridge.

Collet designed to eliminate side load leakage and is removable for o-ring replacement.

"Positive stop" shoulder insures that cartridges are installed to the proper depth

Tube support is machined concentric to cartridge. Cannot interfere with tube insertion nor can it be dislodged or removed.

Encapsulated replaceable o-ring eliminates concerns for out-of-round cavity and leaks due to damaged o-rings.

Self-aligning design allows for consistent installation.

Single diameter cavity

Chamfer required for external seal

- Working pressure: Vacuum to 250 psi (See tubing manufacturer's recommendations for pressure and temperature limitations.)
- Temperature Range: -40°F to 200°F
- Optional o-ring materials are available
- Fewer components to inventory
- Encapsulated design eliminates the accidental omission of components during cartridge installation.
- One piece button collet
- No threads to leak resulting from improper assembly.
- No thread sealants to contaminate air system

† U.S. Patent No. 5,683,120

## Presto Encapsulated Cartridges

### Encapsulated Cartridge PMCEN-replaceable button (PMB listed below)

PART NO.	TUBE SIZE	L	H	O.D.	FLOW DIA. D
PMCEN-2ES	1/8	.59	.18	.406	.094
PMCEN-5/32ES	5/32	.59	.18	.406	.125
PMCEN-3ES	3/16	.59	.18	.437	.156
PMCEN-4ES	1/4	.62	.18	.500	.188
PMCEN-6ES	3/8	.81	.18	.750	.312
PMCEN-8ES	1/2	.94	.18	.875	.375

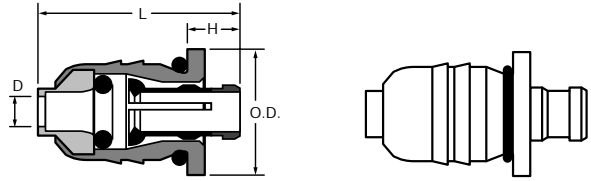

### Encapsulated Cartridge PMTCER-removeable collet and o-ring

PART NO.	TUBE SIZE	L	H	O.D.	FLOW DIA. D
PMT CER-4ES	1/4	.65	.21	.500	.138
PMT CER-6ES	3/8	.84	.21	.750	.215
PMT CER-8ES	1/2	.97	.21	.875	.336
PMT CER-10ES	5/8	1.18	.21	.860	.400
PMT CER-12ES	3/4	1.16	.19	.860	.125

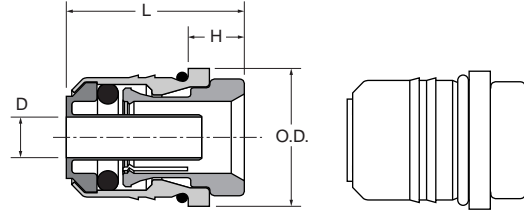

### External Seal ES\*

PART NUMBER	TUBE SIZE	I.D.	W
ES-2†	1/8	.283	.040
ES-3	3/16	.314	.040
ES-4	1/4	.390	.040
ES-6	3/8	.585	.060
ES-8	1/2	.706	.060

\*Material is Nitrite (Buna N), 70 Durometer

† Note: ES2 is to be used with PMCEN-2 and PMCEN-5/32

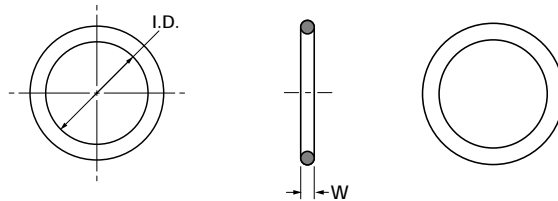

### Removable Cartridge Button PMB

PART NUMBER	TUBE SIZE	O.D.	L
2PMB-X	1/8	.335	.109
5/32PMB-X	5/32	.335	.109
3PMB-X	3/16	.397	.109
4PMB-X	1/4	.460	.109
6PMB-X	3/8	.710	.109
8PMB-X	1/2	.835	.109

Specify Color When Ordering,

Example: 2PMB-BU

Colors Available:

BU-Blue G-Green O-Orange

P-Purple R-Red Y-Yellow

W-White BL-Black GY-Gray

**For PMCEN Cartridges only**

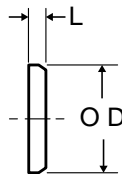

† U.S. Patent No. 5,683,120

**Cartridge Dimensions**

TUBE SIZE	A	B	C DIA.	H DIA.	J
1/8	.18	.21	.406	.18	.10
5/32	.18	.21	.406	.21	.10
3/16	.18	.21	.437	.24	.10
1/4	.18	.21	.500	.31	.10
3/8	.18	.21	.750	.43	.10
1/2	.18	.21	.875	.56	.10

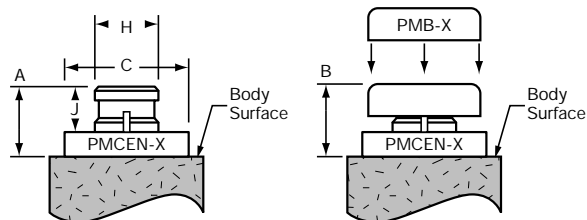

**Cavity Dimensions**

for use with glass filled nylon and acetal

TUBE SIZE	E DIA. ±.002	F DIA. ±.002	G DIA. MIN.	D MIN.
1/8	.326	.358	.094	.43
5/32	.326	.358	.125	.43
3/16	.357	.389	.156	.43
1/4	.433	.465	.188	.46
3/8	.648	.696	.312	.65
1/2	.769	.817	.375	.78
5/8	.898	.946	.500	1.00
3/4	1.103	1.151	.625	1.00

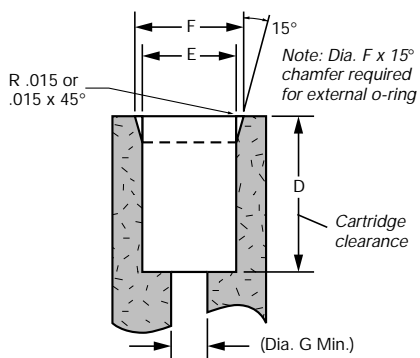

**PMCEN Cartridge Installation Instructions**

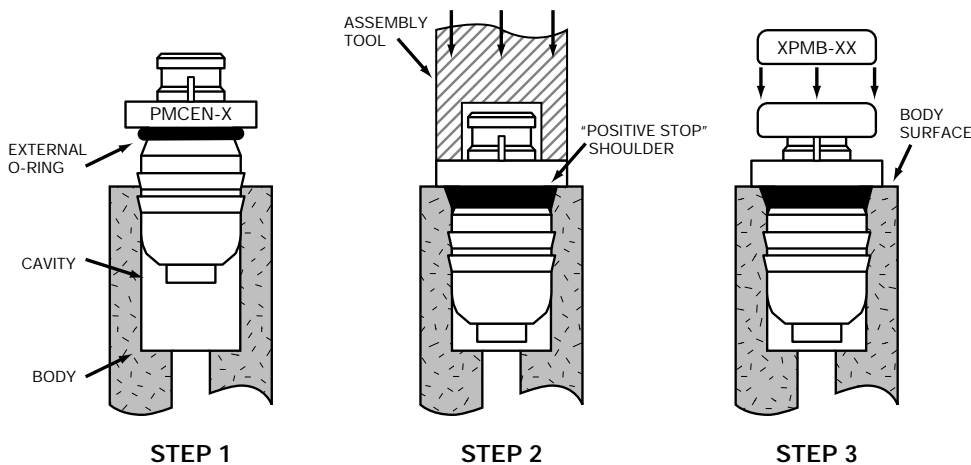

**PMT CER Cartridge Installation Instructions**

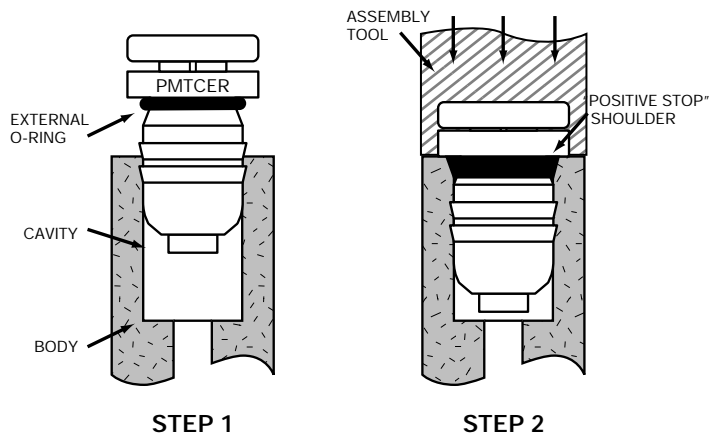

† U.S. Patent No. 5,683,120

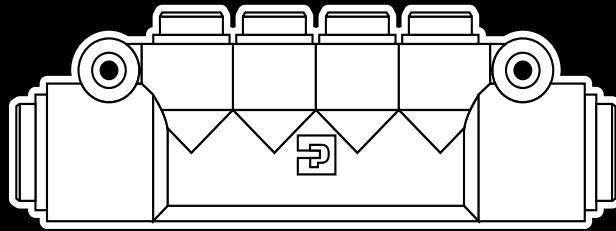

## Presto Manifold

### Advantages

Presto manifolds provide a convenient junction to connect multiple tubing lines for industrial and transportation applications. With their patented\* tube retention design these manifolds meet all of the air brake performance specifications of D.O.T. FMVSS 571.106.

The glass reinforced body is lightweight yet durable. Presto manifolds contain 1/4 or 3/8 O.D. tube inlet ports and 1/4 O.D. tube outlet ports to allow for design and application flexibility. No special tools are needed to assemble. Just bottom the tubing in the port for a positive seal.

### Applications

Suitable for industrial or transportation applications requiring multiple branch connections using Parker Parflex series N Nylon for industrial applications, and Parker Parflex S.A.E. J844 type A & B nylon tubing for all transportation applications. Consult the factory with any questions regarding special product applications prior to use. All applications should be carefully tested through the range of conditions that may be encountered.

### Technical Data

- Body Material: Glass Filled Nylon
- O-Ring Material: Buna N (Nitrile)
- Working Pressure from: Vacuum to 150 PSI
- Working Temperature from: -40° to 200° F  
(Note: See tubing manufacturer's recommendation for pressure and temperature limitations).

### Special Manifolds

Presto Manifold sizes other than those shown in the catalog can be formulated upon request. Die tooling charges may apply to non-standards. It is suggested that a print or sketch with specified buy quantities be submitted with the inquiry.

### Assembly Instructions

1. Cut tubing squarely with Parker tube cutter PTC-001. Be certain that Manifold ports are clean and free of debris.
2. Insert tubing into port until it bottoms. Pull on tubing to verify that it is properly retained in the manifold.
3. To disassemble, simply hold release button against the manifold body and remove the tubing.
4. To reassemble, make certain that the Manifold ports are clean and free of debris and lubricate leading end of the tubing with light oil or petroleum jelly.

### Order

By part number and name.

### Nomenclature

Part numbers are constructed from symbols that identify the size and type of manifold. The first series of letters and numbers identify the style and type of manifold. The second series of numbers describe the tube O.D.

#### Example:

Presto Manifold **24M** **6** **4**  
 Inlet Tube O.D. (6/16)  
 Outlet Tube O.D. (4/16)

### Presto Manifold 24M

PART NO.	TUBE O.D. INLET	TUBE O.D. OUTLET	A	B	D	G	H	M	M1	N
24M-4-4	1/4	1/4	1.33	3.98	.21	2.75	.53	.90	.88	.89
24M-6-4	3/8	1/4	1.33	4.00	.21	2.75	.53	.90	.88	.89

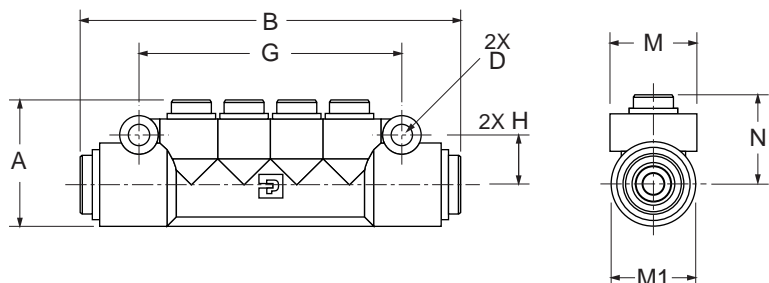

\*U.S. Patent Number 5,683,120