

## Brass Panel Mount Ball Valves Series 502

### Advantages

Parker's forged body ball valve provides extended service life and resists failure caused by severe temperature applications. Optimum flow design assures maximum system efficiency. Highly inert PTFE seats and seals provide resistance to chemical corrosion. Parker also provides a blow-out proof stem, chrome plated brass ball and a specially designed handle enabling increased turning leverage for ease of opening and closing. Parker's ball valve can be readily identified assuring high quality engineering and reliability. This economical ball valve is available in female pipe sizes. Parker's ball valve bodies are machined from high quality CA 377 forgings.

### Applications

Parker's industrial ball valve product line is intended for general purpose use. Please be aware that ball valves are intended for use in the fully open or closed positions. Depending on application conditions, throttling of the valve may result in premature seal failure and/or inability to turn the valve handle.

For use as fuel line shutoffs for gasoline and diesel powered over the highway, off highway, and construction equipment vehicles. Water and air service lines on capital equipment and plant design plumbing that require total shutoff capability.

### Working Pressure and Temperature

Saturated steam service up to 150 PSI and 400° F  
 Vacuum, 29 Inches of Mercury  
 Vented up to 250 PSI

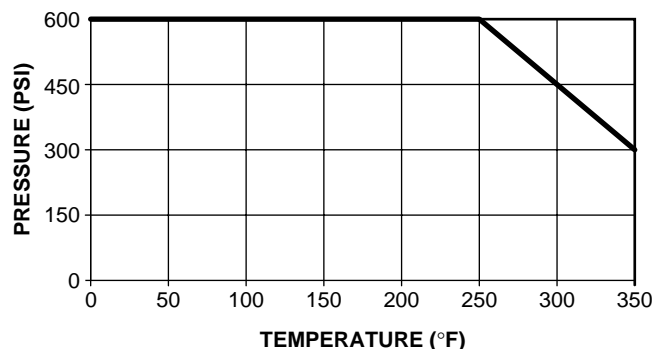

### Operating Instructions

Quarter turn is "ON" or "OFF".  
 (Provides positive stop action for full shutoff.)

**NOTE:** PERIODICALLY CHECK THE ADJUSTABLE PACKING NUT AND TIGHTEN AS REQUIRED.

Style	Type	Material	Size	Options
V	502	P	-4	-00
Style	V-Valve VP-Valve, Padlocking Handle VV-Valve, Vented VVP-Valve, Vented, Padlocking Handle			
Type	502-Female/Female PTF Ports			
Material	P- Brass PN-Nickel Plated			
Size	4-1/4" 6-3/8" 8-1/2" 12-3/4" 16-1"			
Options	01-Stainless Steel Ball & Stem 02-Stainless Steel Handle & Nut 03-Stainless Steel Ball, Stem, Handle & Nut 04-Tee Handle 08-Unmarked Yellow Vinyl Handle Cover 21-Oval Handle			

### Flow Data

VALVE SIZE	CV
1/4	4.0
3/8	5.8
1/2	12.0
3/4	35.0
1	54.0

### Mounting detail for all sizes

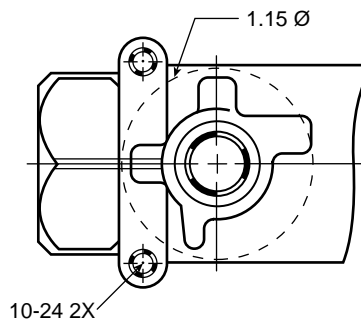

**Female-Female Pipe Ends, Panel Mount XV502P**

PART NO.	SIZE	B HEX	C HEX	F	G	H	L	M	N	FLOW DIA. D
XV502P-4	1/4	15/16	15/16	.50	1.12	3.96	4.90	2.03	2.47	.375
XV502P-6	3/8	15/16	15/16	.50	1.12	3.96	4.90	2.03	2.47	.375
XV502P-8	1/2	1-1/16	1-1/16	.50	1.12	3.96	5.00	2.20	2.58	.500
XV502P-12	3/4*	1-1/4	1-5/16	.87	1.37	3.96	5.25	2.42	2.81	.685
XV502P-16	1*	1-1/2	1-9/16	.87	1.37	3.96	5.34	2.75	3.08	.875

\*Special Short

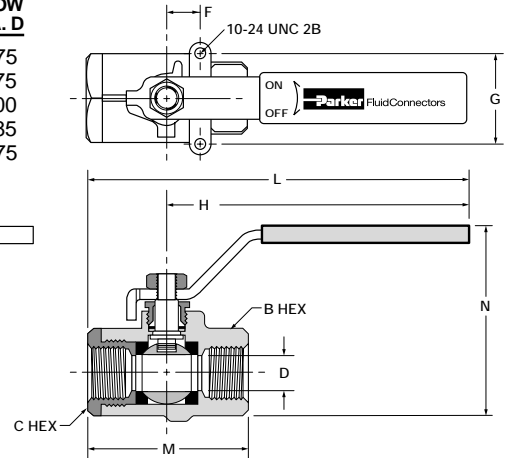
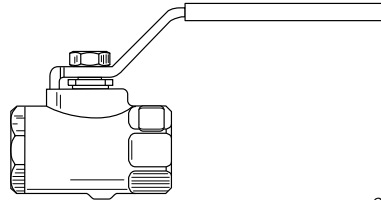

**Vented, Female-Female Pipe Ends, Panel Mount XVV502P**

PART NO.	PIPE THD.	B HEX	C HEX	F	G	K	H	L	M	N	D FLOW Ø
XVV502P-4	1/4	15/16	15/16	.50	1.12	1.11	3.96	4.90	2.03	2.47	.375
XVV502P-6	3/8	15/16	15/16	.50	1.12	1.11	3.96	4.90	2.03	2.47	.375
XVV502P-8	1/2	1-1/16	1-1/16	.50	1.12	1.23	3.96	5.00	2.20	2.58	.500
XVV502P-12	3/4*	1-1/4	1-5/16	.87	1.37	1.45	3.96	5.25	2.42	2.81	.685
XVV502P-16	1*	1-1/2	1-9/16	.87	1.37	1.58	3.96	5.34	2.75	3.08	.875

\*Special Short

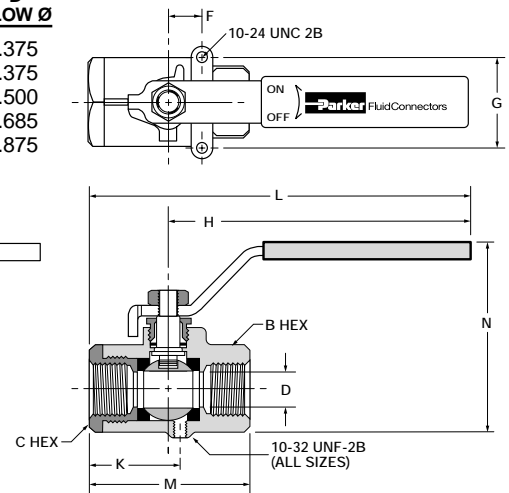
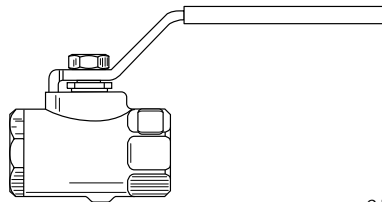

**Locking Handle, Female Pipe Ends, PanelMount XVP502P**

PART NO.	SIZE	B HEX	C HEX	F	G	H	L	M	N	D FLOW Ø
XVP502P-4	1/4	15/16	15/16	.50	1.12	3.96	4.90	2.03	2.47	.375
XVP502P-6	3/8	15/16	15/16	.50	1.12	3.96	4.90	2.03	2.47	.375
XVP502P-8	1/2	1-1/16	1-1/16	.50	1.12	3.96	5.00	2.20	2.58	.500
XVP502P-12	3/4*	1-1/4	1-5/16	.87	1.37	3.96	5.25	2.42	2.81	.685
XVP502P-16	1*	1-1/2	1-9/16	.87	1.37	3.96	5.34	2.75	3.08	.875

For use with 5/16" Ø shank lock

\*Special Short

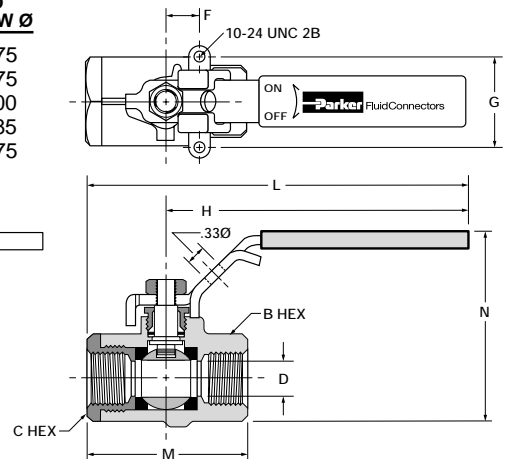
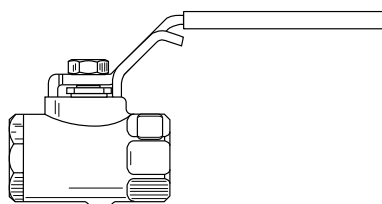

# Panel Mount Ball Valves Series 502

## OSHA 29 CFR Part 1910 Vented, Locking Handle, Female Pipe Ends, Panel Mount XVVP502P

PART NO.	PIPE THD.	B HEX	C HEX	F	G	K	H	L	M	N	D FLOW Ø
XVVP502P-4	1/4	15/16	15/16	.50	1.12	1.11	3.96	4.90	2.03	2.47	.375
XVVP502P-6	3/8	15/16	15/16	.50	1.12	1.11	3.96	4.90	2.03	2.47	.375
XVVP502P-8	1/2	1-1/16	1-1/16	.50	1.12	1.23	3.96	5.00	2.20	2.58	.500
XVVP502P-12	3/4*	1-1/4	1-5/16	.87	1.37	1.45	3.96	5.25	2.42	2.81	.685
XVVP502P-16	1*	1-1/2	1-9/16	.87	1.37	1.58	3.96	5.34	2.75	3.08	.875

For use with 5/16" Ø shank lock

\*Special Short

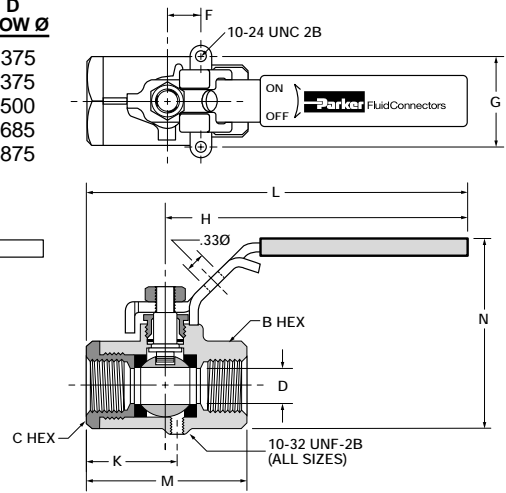
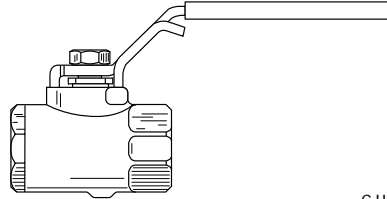

## Tee Handle, Female Pipe Ends, Panel Mount XV502P-X-04

PART NO.	SIZE	B HEX	C HEX	F	G	H	L	M	N	D FLOW Ø
XV502P-4-04	1/4	15/16	15/16	.50	1.12	1.25	2.50	2.03	1.87	.375
XV502P-6-04	3/8	15/16	15/16	.50	1.12	1.25	2.50	2.03	1.87	.375
XV502P-8-04	1/2	1-1/16	1-1/16	.50	1.12	1.25	2.50	2.20	1.98	.500
XV502P-12-04	3/4*	1-1/4	1-5/16	.87	1.37	1.25	2.50	2.42	2.20	.685
XV502P-16-04	1*	1-1/2	1-9/16	.87	1.37	1.25	2.50	2.75	2.48	.875

\*Special Short

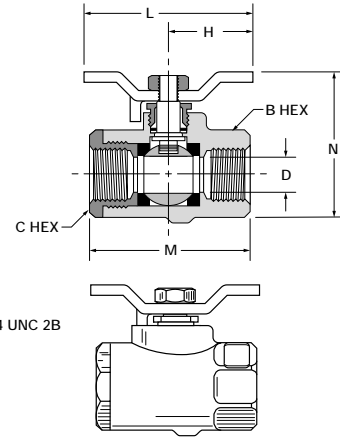
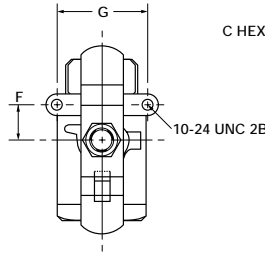

## Oval Handle, Female Pipe Ends, Panel Mount XV502P-X-21

PART NO.	SIZE	B HEX	C HEX	F	G	H	L	M	N	D FLOW Ø
XV502P-4-21	1/4	15/16	15/16	.50	1.12	1.74	3.49	2.03	2.38	.375
XV502P-6-21	3/8	15/16	15/16	.50	1.12	1.74	3.49	2.03	2.38	.375
XV502P-8-21	1/2	1-1/16	1-1/16	.50	1.12	1.74	3.49	2.20	2.49	.500
XV502P-12-21	3/4*	1-1/4	1-5/16	.87	1.37	1.74	3.48	2.42	2.71	.685
XV502P-16-21	1*	1-1/2	1-9/16	.87	1.37	1.74	3.48	2.75	2.99	.875

\*Special Short

