

WASHERS

GLOBALLOY LOCKWASHERS

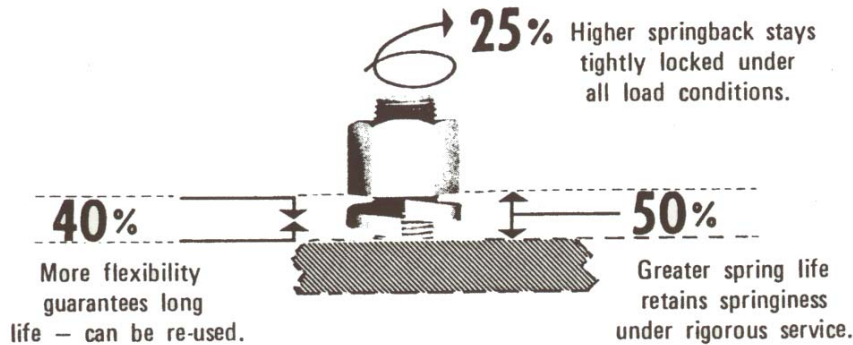

- **ASSURE LONGER EQUIPMENT LIFE**

- COMPENSATE FOR WEAR THROUGH INCREASED SPRING TENSION
- REDUCE LOSS IN TIGHTNESS DUE TO VIBRATION
- GREATER STRENGTH AND HOLDING POWER

- **SPECIAL ALLOY STEEL**

- GREATER TENSION, WILL NOT WARP
- RETAIN STRENGTH UP TO 800°F
- ELIMINATE CRACKING AND BREAKAGE

- **Impregno-Plated** FOR MAXIMUM PROTECTION AGAINST RUST AND CORROSION

PART #	DESCRIPTION	PACK
W13-660056	# 6 GLOBALLOY LOCKWASHER IMP	(FAA)
W13-660058	# 8 GLOBALLOY LOCKWASHER IMP	(FAA)
W13-660060	#10 GLOBALLOY LOCKWASHER IMP	(FAA)
W13-660062	1/4 GLOBALLOY LOCKWASHER IMP	(FAA)
W13-660064	5/16 GLOBALLOY LOCKWASHER IMP	(CFA)
W13-660066	3/8 GLOBALLOY LOCKWASHER IMP	(CFA)
W13-660068	7/16 GLOBALLOY LOCKWASHER IMP	(BAA)
W13-660070	1/2 GLOBALLOY LOCKWASHER IMP	(BAA)
W13-660072	9/16 GLOBALLOY LOCKWASHER IMP	(BAA)
W13-660074	5/8 GLOBALLOY LOCKWASHER IMP	(BAA)
W13-660076	3/4 GLOBALLOY LOCKWASHER IMP	(BAA)
W13-660078	7/8 GLOBALLOY LOCKWASHER IMP	(FA)
W13-660080	1" GLOBALLOY LOCKWASHER IMP	(FA)
W13-660082	1-1/8 GLOBALLOY LOCKWASHER IMP	(CF)
W13-660084	1-1/4 GLOBALLOY LOCKWASHER IMP	(CF)
W13-660086	1-1/2 GLOBALLOY LOCKWASHER IMP	(BA)

GLOBALLOY LOCKWASHERS
ARE DESIGNED TO CUT YOUR MAINTENANCE COSTS



GLOBAL INDUSTRIAL PRODUCTS